

# Premium Range

TRUCKS | TRAILERS | PORTABLE UNITS



**Vacuum Truck Supplies**

QUALITY - INTEGRITY - COMMITMENT



**Getting to know VTS 4**

■ Making it right for Australian Pumpers	4
■ Our 'Ready-to-Earn' Philosophy	5
■ New to VTS? Build & Product Ready Reckoner	32

**VTS Premium Trucks 6**

■ MudVac	8
■ LiquidVac	10
■ LiteVac	12
■ DiggerVac	14
■ DrainVac	16

**VTS Premium Tankers 18**

■ TipperVac	20
■ TriVac	22

**VTS Premium Portables 24**

■ HookVac 10,000	26
■ Evac 800	28
■ Evac 1,600	30
■ Evac 3,200	32





**Made right for  
Australia since  
1998.**

Vacuum Truck Supplies (VTS) was founded by service operators, who understand what goes into a successful pumping operation.

### About VTS

We are industry leaders in quality, design and engineering of vacuum tanker manufacturing for over 25 years. Our passion for the job is our point of difference.

We have built and supplied over 1,000 trucks, trailers and portable units for operators Australia wide and we make sure our customers have the right equipment, training and ongoing support to run their business.

### Our 'Ready-to-Earn' Philosophy

All VTS tankers are purposefully designed to sustain maximised income for our customers.

Our in-house engineers and manufacturing team carefully consider every detail to achieve the highest standards of longevity and performance, making sure your VTS tanker is the best you've ever had.



# Premium Trucks

## Volvo Cab Chassis

We have chosen Volvo as the cab chassis for the trucks within our Premium Range; and partnered with CMV Truck and Bus to ensure you enjoy unrivaled access and continual after sales support.

## Rugged Construction

VTS specification provides long-term trouble-free ownership.

## Simple Operation

Minimal training required for safe and efficient operation.

## Easy to Maintain

More time on the job, less time in the workshop.

## Fit for Purpose

Quiet, logical operation; great for most liquified and liquid wastes.



MAXIMISED  
WASTE CAPACITY

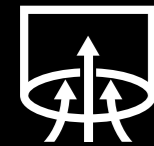

HIGH PERFORMANCE  
VACUUM PUMP

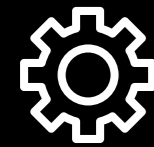

MINIMISED  
DOWNTIME



## MudVac

10,000L

Designed for liquid,  
sludge and mud.



## LiquidVac

11,000L

Designed for  
liquid waste.



## LiteVac

12,500L

Designed for sludges  
and liquid waste.



## DiggerVac

7,000L

Designed for  
hydro excavation.



## DrainVac

7,000L

Designed for drain cleaning  
and hydro excavation.

## Quality System

- Hydraulically driven Liquid Ring Vacuum Pump 1,000 m<sup>3</sup>/h – 600 CFM
- Molex inlet valve
- Hydraulic tip function
- Stainless steel separator and manifolding
- 10,000 litre mild-steel barrel made to AS1210 CL3
- Volvo FE 350hp 6x4 with I-Shift
- 1,200 litres of fresh water with 26 LPM/210 BAR Water Pump



# MudVac 10,000L



DESIGNED FOR LIQUID,  
SLUDGES AND MUDS

10,000L  
Capacity

Steel, tipping, full opening  
rear door vacuum tank

1,000 m<sup>3</sup>/h – 600 CFM  
Liquid Ring Vacuum Pump

1,200 litres  
of fresh water

26 LPM/210 BAR  
water pump

AS1210 CL3 and  
AS4343 compliant



# LiquidVac

## 11,000L



DESIGNED FOR  
LIQUID WASTES



11,000L  
Capacity

Mild steel, tipping,  
vacuum tank

1,000 m<sup>3</sup>/h – 600 CFM  
Liquid Ring Vacuum Pump

1,200 litres of fresh water with  
26 LPM/210 BAR water pump

AS1210 CL3 and  
AS4343 compliant

### Quality System

- Hydraulically driven Liquid Ring Vacuum Pump 1,000 m<sup>3</sup>/h – 600 CFM
- Molex inlet valve
- Hydraulic tip function
- Stainless steel separator and manifolding
- 11,000 litre mild-steel barrel made to AS1210 CL3
- Volvo FE 350hp 6x4 with I-Shift
- 1,200 litres of fresh water with 26 LPM/210 BAR Water Pump



## Quality System

- Hydraulically driven Liquid Ring Vacuum Pump 1,000 m<sup>3</sup>/h – 600 CFM
- Molex inlet valve
- Hydraulic tip function
- Stainless steel separator and manifolding
- 12,500 litre aluminium barrel made to AS1210 CL3
- Volvo FE 350hp 6x4 with I-Shift
- 1,000 litres of fresh water with 26 LPM/210 BAR Water Pump



# LiteVac 12,500L



DESIGNED FOR  
LIQUID WASTES

12,500L  
Capacity

Aluminium, tipping,  
vacuum tank

1,000 m<sup>3</sup>/h – 600 CFM  
Liquid Ring Vacuum Pump

1,000 litres  
of fresh water

26 LPM/210 BAR  
water pump

AS1210 CL3 and  
AS4343 compliant



# DiggerVac

## 6x4 | 8x4



A VERSATILE AND MODERN  
SOLUTION FOR HYDRO EXCAVATION



5mm 304 stainless  
steel barrel

Hydraulic tipping and  
full opening rear door

Fully hydraulic  
150mm suction boom

UDOR NDD pump 17 LPM/300 BAR  
12mm 35m spring retractable hose reel

Simplified control system:  
no computers, no worries!

### DiggerVac 7,000

- Capacity: 7,000L Waste, 3,500L Water
- Cab Chassis: Volvo FE 350hp 6x4 with I-Shift
- **Vacuum Pump: 4,000 m<sup>3</sup>/h – 2,350 CFM**  
Jurop Helix blower, belt driven

### DiggerVac 9,000

- Capacity: 9,000L Waste, 4,000L Water
- Cab Chassis: Volvo FM 450 HP 8x4
- **Vacuum Pump: 6,100 m<sup>3</sup>/h – 3,590 CFM**  
Jurop Helix blower, belt driven



### DrainVac 7,000

- Capacity: 7,000L Sludge, 3,500L Water
- Cab Chassis: Volvo FE 350hp 6x4 with I-Shift
- Pratissoli Drain cleaning pump  
270 LPM/155 BAR, 25mm 180m hydraulic drive hose reel
- **Vacuum Pump: 3,050 m<sup>3</sup>/h – 1,800 CFM CVS liquid ring vacuum pump, belt driven**

### DrainVac 8,000

- Capacity: 8,000L Sludge, 4,000L Water
- Cab Chassis: Volvo FM 450 HP 8x4
- Pratissoli Drain cleaning pump  
346 LPM/170 BAR, 25mm 180m hydraulic drive hose reel
- **Vacuum Pump: 4,000 m<sup>3</sup>/h – 2,350 CFM CVS liquid ring vacuum pump, belt driven**



# DrainVac

## 6x4 | 8x4



A VERSATILE AND MODERN SOLUTION FOR DRAIN CLEANING AND HYDRO EXCAVATION

5mm 304 stainless steel barrel

Hydraulic tipping and full opening rear door

Fully hydraulic 150mm suction boom

UDOR NDD pump 17 LPM/300 BAR 12mm 35m spring retractable hose reel

Pratissoli Drain cleaning pumps with 25mm 180m hydraulic drive hose reel

Simplified control system: no computers, no worries!



# Premium Tankers

### Self-contained

Put it behind any suitable truck, any time, anywhere.

### Rugged Construction

Long term trouble free ownership.

### Simple Operation

Minimal training required for safe and efficient operation.

### Easy to Maintain

More time on the job, less time in the workshop.

### Fit for Purpose

Designed for sludges, muds, and bulk liquid waste. Assisted off loading, vacuum loading and pressure unloading.

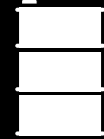

BULK WASTE SOLUTION



SELF-CONTAINED VACUUM AND HYDRAULIC SYSTEM



MINIMISED DOWNTIME



## TipperVac

22,000L

Designed for bulk sludges and mud waste.



## TriVac

24,000L

Designed for bulk liquid waste. Fully self-contained vacuum system.



## Quality System

- CAT watercooled diesel motor
- Molex ball valves
- Air bag suspension
- Wabco ABS / EBS system
- Now available with Pompetravaini TRVX 1007 Liquid Ring pump



# TipperVac 22,000L



DESIGNED FOR BULK LIQUID,  
SLUDGES AND MUDS

22,000L  
Capacity

25° tip angle and full  
opening rear door

Fully self-contained vacuum  
and hydraulic system

Self-contained: put it  
behind any truck

On-board fresh water and  
high pressure water pump

AS1210 CL3 and  
AS4343 compliant



# TriVac 24,000L



DESIGNED FOR  
BULK LIQUID WASTE



24,000L  
Capacity

Fully self-contained  
vacuum system

Self-contained: put it  
behind any truck

Available with either vane  
or liquid ring vacuum pump

AS1210 CL3 and  
AS4343 compliant

## Quality System

- Masport Vacuum Pump
- On-board diesel motor
- Molex ball valves
- Air bag suspension
- Wabco ABS / EBS system
- Now available with Pompetravaini TRVX 1007 Liquid Ring pump



# Premium Portables

## All forms of liquid/sludge waste

Sewerage, septic, portable toilet, feedlot/ agricultural sludges, aquaculture/fish waste, industrial, concrete cutting waste, paint booth sludges, communication pits, oily waters, waste cooking oil, and many other wastes.

## Rugged Construction

Proven rugged design, coupled with stainless steel construction for wet areas means our EVac range will last a very long time.

## Quality Components

Top quality European and USA componentry; coupled with VTS's 'simple is more' design makes for a cost effective and practical solution.

## Australian Standards

The VTS EVac range meets AS1210 for Pressure Vessels and AS4343 for Hazard Levels.



FULLY COMPLIANT WITH AUSTRALIAN STANDARDS



HIGH PERFORMANCE VACUUM OPERATION



HIGH PERFORMANCE PRESSURE OPERATION



## HookVac

10,000L

Designed for you to add liquid waste to your hooklift fleet.



## Evac 800

300L Fresh Water  
800L Waste Capacity

Suited to all forms of liquid and sludge waste.



## Evac 1,600

600L Fresh Water  
1,600L Waste Capacity

Suited to all forms of liquid and sludge waste.



## Evac 3,200

1200L Fresh Water  
3,200L Waste Capacity

Suited to all forms of liquid and sludge waste.



## All the benefits of the VTS Range

- Durable and robust construction
- Simple operation and maintenance
- Increased utilisation
- Purpose build to the same high quality as all our systems
- Self-contained for ultimate flexibility
- Simple solution for complex problems
- Create a better bottom line.



Operates on or off any suitable hooklift truck

10,000L mild steel vacuum tank, designed to AS1210 CL3

# HookVac 10,000L



DESIGNED FOR YOU TO ADD LIQUID WASTE TO YOUR HOOKLIFT FLEET

Fully self-contained Masport Cobra vacuum package (920 m<sup>3</sup>/h – 540 CFM) belt driven by Deutz diesel 1.2 25hp auxiliary engine



### Vacuum Tank

- Constructed from 5mm GR304 stainless steel
- Mounted on a mild steel skid frame, able to be forklifted from all four sides
- Top wash out man-way
- Sight glasses to observe waste level in tank
- Tie down and lifting points

### Vacuum System

- 50mm vacuum system, 10m suction hose fitted with 75mm inlet to tank and blockage access
- 75mm discharge valve
- Primary, secondary shutoff
- Oil catch muffler
- Pressure relief valve and vacuum relief valve
- Vacuum and pressure gauge

### Water System

- 300 litre fresh water capacity with sight tube
- Retractable steel hose reel with 20m of water delivery hose
- Petrol powered water pump, 25mm

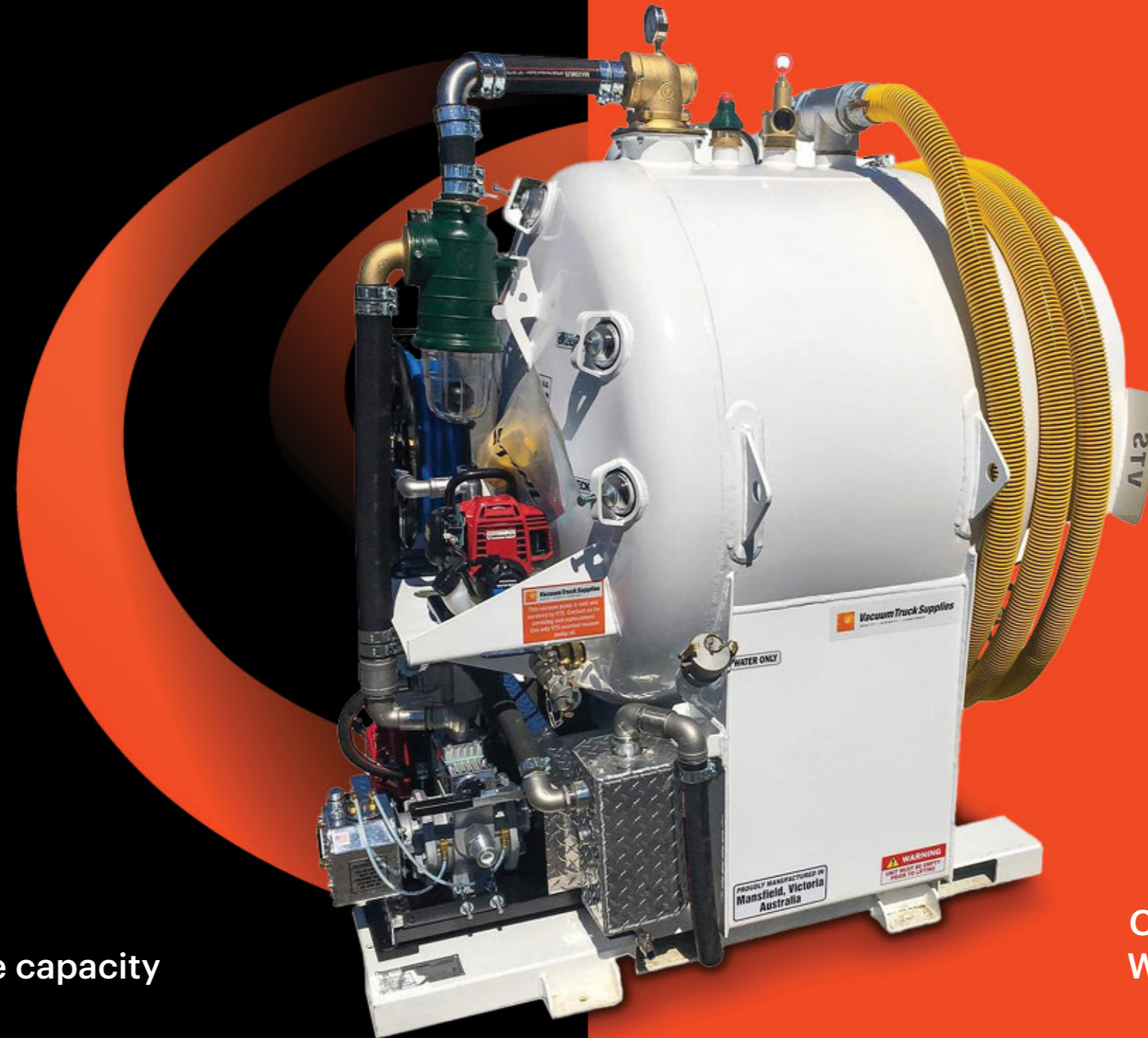

# Evac 800



SUITED TO ALL FORMS OF LIQUID AND SLUDGE WASTES\*

\*Not designed for hydro excavation or DG wastes

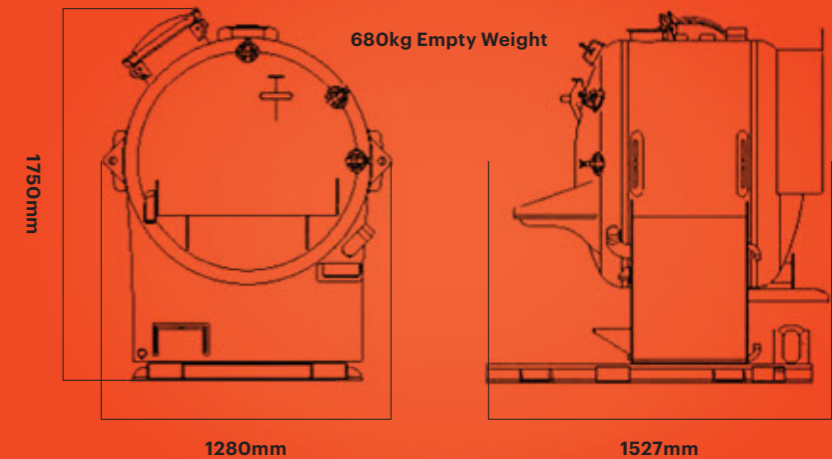

**Stainless steel construction**

**300L water capacity**

**800L waste capacity**

**Can be registered with Worksafe as plant equipment**

**AS1210 CL3 and AS4343 compliant**



### Vacuum Tank

- Constructed from 5mm GR304 stainless steel
- Mounted on a mild steel skid frame, able to be forklifted from all four sides
- Top wash out man-way
- Sight glasses to observe waste level in tank
- Tie down and lifting points

### Vacuum System

- 50mm vacuum system, 10m suction hose fitted with 75mm inlet to tank and blockage access
- 75mm discharge valve
- Primary, secondary shutoff
- Oil catch muffler
- Pressure relief valve and vacuum relief valve
- Vacuum and pressure gauge

### Water System

- 600 litre fresh water capacity with sight tube
- Retractable steel hose reel with 20m of water delivery hose
- Petrol powered water pump, 25mm



# Evac 1,600



SUITED TO ALL FORMS OF LIQUID AND SLUDGE WASTES\*

\*Not designed for hydro excavation or DG wastes

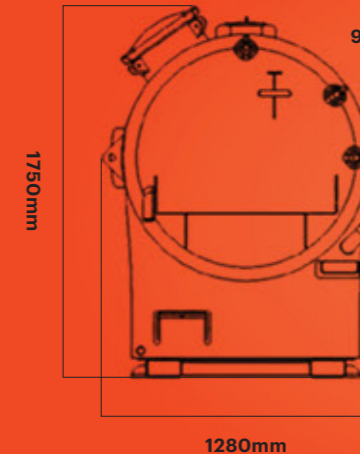

950kg Empty Weight

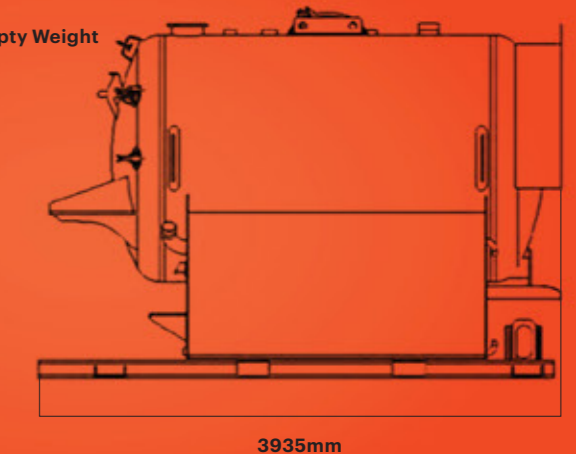

Stainless steel construction

600L water capacity

1,600L waste capacity

Can be registered with Worksafe as plant equipment

AS1210 CL3 and AS4343 compliant

### Vacuum Tank

- Constructed from 5mm GR304 stainless steel
- Mounted on a mild steel skid frame, able to be forklifted from all four sides
- Top wash out man-way
- Sight glasses to observe waste level in tank
- Tie down and lifting points

### Vacuum System

- 50mm vacuum system, 10m suction hose fitted with 75mm inlet to tank and blockage access
- 75mm discharge valve
- Primary, secondary shutoff
- Oil catch muffler
- Pressure relief valve and vacuum relief valve
- Vacuum and pressure gauge

### Water System

- 1,200 litre fresh water capacity with sight tube
- Petrol powered water pump, 25mm
- Retractable steel hose reel with 20m of water delivery hose



# Evac 3,200



SUITED TO ALL FORMS OF LIQUID AND SLUDGE WASTES\*

\*Not designed for hydro excavation or DG wastes

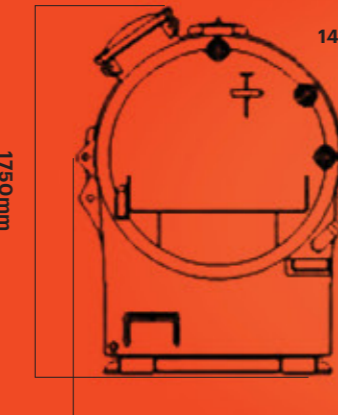

1460kg Empty Weight

1280mm

1750mm

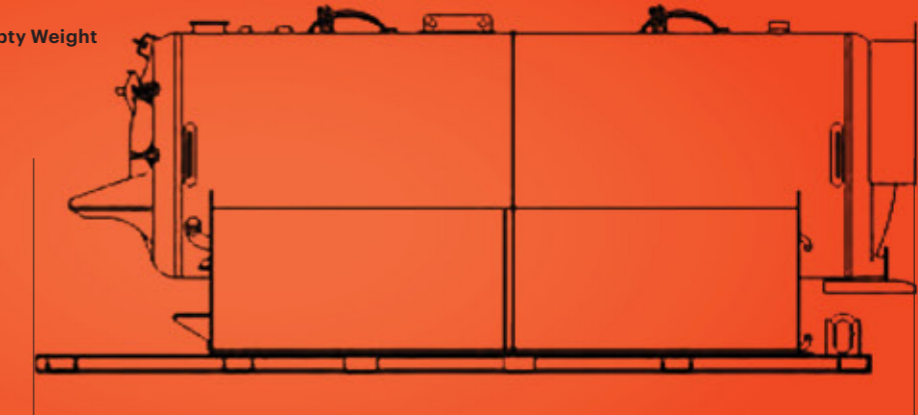

3985mm

Stainless steel construction

1,200L water capacity

3,200L waste capacity

Can be registered with Worksafe as plant equipment

AS1210 CL3 and AS4343 compliant



Premium Trucks	Waste Capacity	Water Capacity	Vacuum Pump	Vacuum Tank	Transportation	Suitability
<b>MudVac 10,000</b>	10,000L	1,200L	1,000 m <sup>3</sup> /h 600 CFM	Steel	Volvo FE350hp 6 x 4 I-Shift	Designed for liquid, sludge and mud
<b>LiquidVac 11,000</b>	11,000L	1,200L	1,000 m <sup>3</sup> /h 600 CFM	Mild Steel	Volvo FE350hp 6 x 4 I-Shift	Designed for liquid wastes
<b>LiteVac 12,500</b>	12,500L	1,000L	1,000 m <sup>3</sup> /h 600 CFM	Aluminium	Volvo FE350hp 6 x 4 I-Shift	Designed for liquid wastes
<b>DiggerVac 7,000</b>	7,000L	3,500L	4,000 m <sup>3</sup> /h 2,350 CFM	Stainless Steel	Volvo FE350hp 6 x 4 I-Shift	Designed for hydro excavation
<b>DiggerVac 9,000</b>	9,000L	4,000L	6,100 m <sup>3</sup> /h 3,590 CFM	Stainless Steel	Volvo FM450hp 8 x 4	Designed for hydro excavation
<b>DrainVac 7,000</b>	7,000L	3,500L	3,050 m <sup>3</sup> /h 1,800 CFM	Stainless Steel	Volvo FE350hp 6 x 4 I-Shift	Designed for drain cleaning and hydro excavation
<b>DrainVac 8,000</b>	8,000L	4,000L	4,000 m <sup>3</sup> /h 2,350 CFM	Stainless Steel	Volvo FM450hp 8 x 4	Designed for drain cleaning and hydro excavation

Premium Tankers	Waste Capacity	Water Capacity	Vacuum Pump*	Suspension	Transportation	Suitability
<b>TipperVac 22,000</b>	22,000L	3,300L	1,000 m <sup>3</sup> /h 600 CFM	Fuwa Khitch air bag	Your choice of truck	Designed bulk sludges and liquid wastes
<b>TriVac 24,000</b>	24,000L	—	1,000 m <sup>3</sup> /h 600 CFM	Fuwa Khitch air bag	Your choice of truck	Designed for bulk liquid wastes

\* Now available with Pompetravaini TRVX 1007 Liquid Ring pump

Premium Portables	Waste Capacity	Water Capacity	Vacuum Pump	Empty Weight	Transportation	Suitability
<b>EVac 800</b>	800L	300L	120 m <sup>3</sup> /h 70 CFM	680kg	Mild steel skid frame mount, forklift capable	All forms of liquid / sludge wastes
<b>EVac 1,600</b>	1,600L	600L	195 m <sup>3</sup> /h 115 CFM	950kg	Mild steel skid frame mount, forklift capable	All forms of liquid / sludge wastes
<b>EVac 3,200</b>	3,200L	1,200L	195 m <sup>3</sup> /h 115 CFM	1,460kg	Mild steel skid frame mount, forklift capable	All forms of liquid / sludge wastes
<b>HookVac 10,000</b>	10,000L	—	920 m <sup>3</sup> /h 540 CFM	N/A	Mild steel skid frame mount, hooklift truck transportable	All forms of liquid / sludge wastes

## VTS Ready Reckoner

### Specialised Design

We've combined learnings from over 1,000 builds into the design of each of our Premium Range units. You can be sure that on delivery day, your unit will be 'ready-to-earn'.

### Simplified Maintenance

Intelligent design and only the highest quality components work together to keep you on the road.

### Leading Delivery Turnaround

Strategic partnerships and streamlined design and build processes means an unbeatable delivery turnaround for every VTS customer.

# We are Engineers, Boilermakers, Fabricators, Technicians, and Welders.

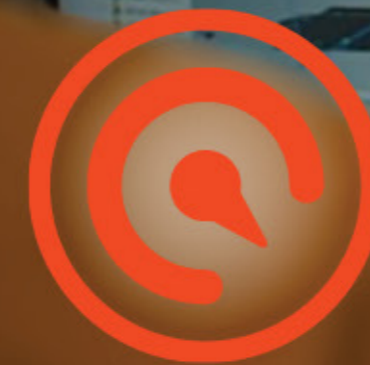

MAXIMISED  
WASTE CAPACITY



HIGH PERFORMANCE  
VACUUM PUMP



MINIMISED  
DOWNTIME



## VTS & NozzTeq® – Problem solvers and system suppliers.

NozzTeq® was founded in 2006, as daughter company in the United States of the parent company AquaTeq® located in Sweden. AquaTeq® noticed deficiencies in nozzle designs of the time, so took on the challenge to increase nozzle efficiency for the sewer and storm water cleaning industry. With their proven innovation of the designs, they brought that to North America, hence the forming of NozzTeq®.

Throughout the years they have created several new products, so unique that they have been patented both in the United States and internationally. VTS are Industry Leaders in quality, design and engineering of vacuum tanker manufacturing for over 25 years. Our passion for the job is our point of difference.

We have built and supplied over 1,000 trucks, trailers and portable units for operators Australia wide and we make sure our customers have the right equipment, training and ongoing support to run their business. Come to us with your problems and we will develop a tailor-made solution that will perform with the highest efficiency, lowest possible energy consumption and is fit for purpose.

## VTS & Volvo; a partnership built for you.



For the trucks within our Premium Range we have chosen Volvo as the cab chassis. To ensure VTS customers enjoy unrivaled access and support, we have partnered with CMV Truck and Bus.

This connects VTS directly with Volvo's factories for the ordering as well as their extensive Australian dealer network for unbeatable after sales support.

### For you this means:—

#### A focus on 'Whole-of-Life' ownership

The revered i-Shift auto transmission is just one way that a Volvo truck provides your business with an easier driver experience, reduced operational costs, minimised downtime and increased product longevity.

#### Access to leading power and engineering

- 30,000km maintenance intervals
- Reduced fuel consumption
- Heavy duty chassis for longer life
- Rapid response EBS system
- Air bag suspension
- Automated fuel efficiency and location data collection via Volvo connect app

#### World-class safety

With Swedish Cab Test Standard construction and global safety initiatives, we trust Volvo to never cut corners.

#### Quicker delivery

Dramatically reduced delivery turnaround is a key part of our 'Ready-to-Earn' philosophy. It's what gets VTS customers earning sooner.







**Vacuum Truck Supplies**

18 Crosbys Lane Mansfield  
Victoria, 3722 Australia

**Phone**

General  
(03) 5775 7300

Sales  
1800 822 787

**Email**

General  
info@vacuumtrucks.com.au

Sales  
sales@vacuumtrucks.com.au

**Mail**

Vacuum Truck Supplies  
PO Box 556, Mansfield  
Victoria 3724, Australia

[vacuumtrucks.com.au](http://vacuumtrucks.com.au)



***Vacuum Truck Supplies***

QUALITY - INTEGRITY - COMMITMENT